

LOG TURNER VLT-1200

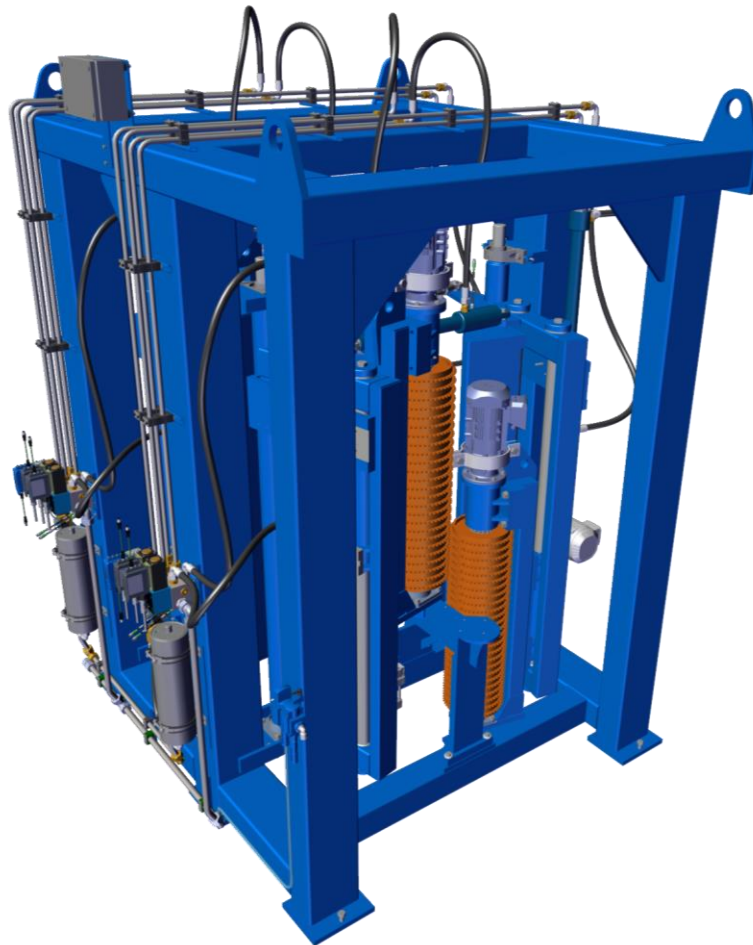

- ✓ For higher yeild
- ✓ High measurement accuracy
- ✓ Higher speed



LOG TURNER VLT-1200 consists of double pairs of vertical serrated rolls with servo-hydraulic centering and separate drives. The four rollers are movable vertically, i.e. up and down via a guide system.

The rollers, which are mounted in pairs on centering frames, are operated up and down via servo-hydraulic cylinders.

When turning, the rollers are positioned up on the right side and down on the left side, depending on which direction the log is to be turned.



VLT-1200

- Higher speed with double log turners 200 m / min



Measure:

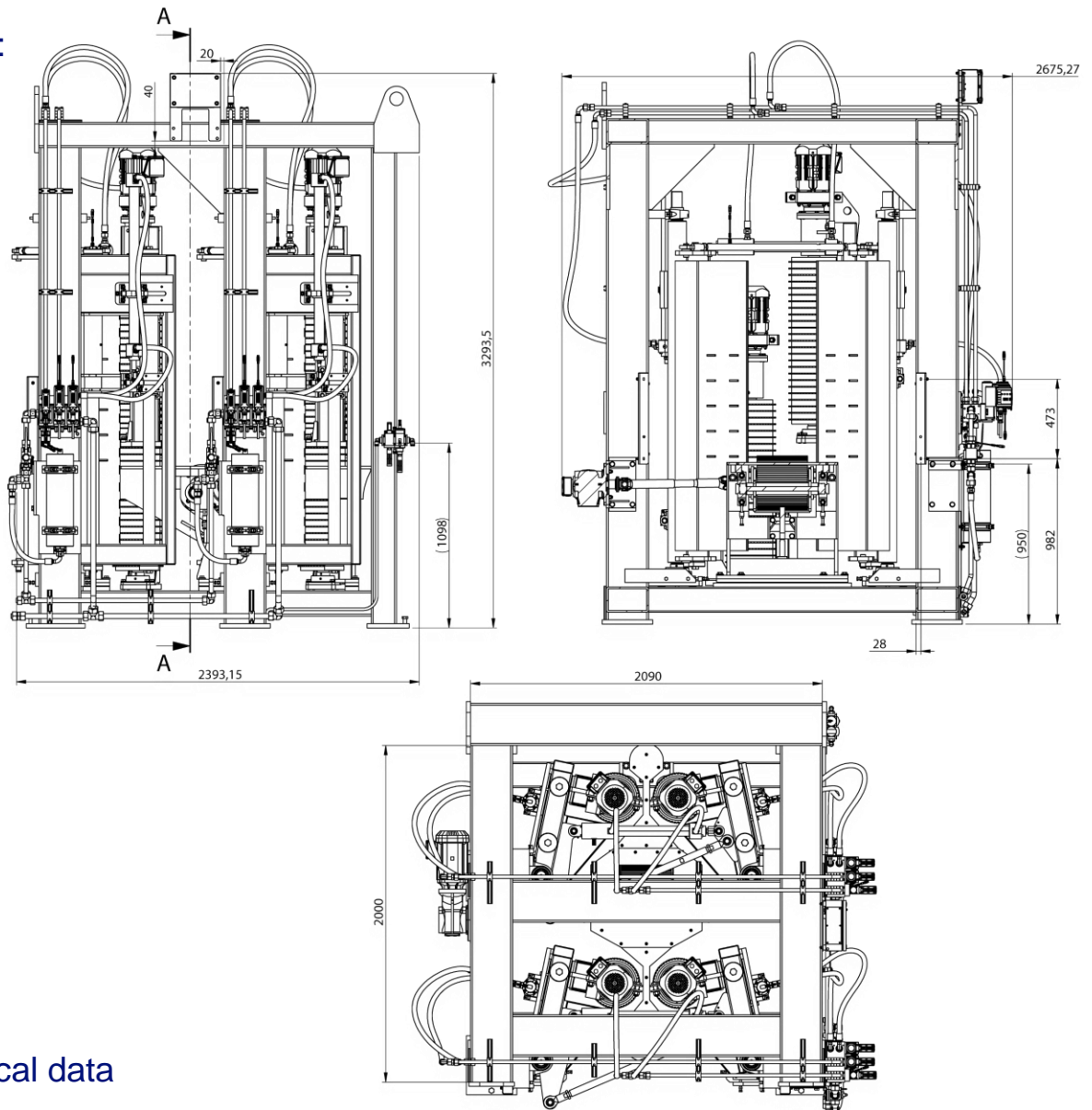

Technical data

Max feed speed.....	200m/min
Min log length	2 m
Min log hatch.....	ca 0,3 m
Max / Min log diameter enclosed	600/ 80 mm
Capacity.....	approx. 50 pcs/min
Weight.....	ca 2 ton

Rounding precision

Log diameter	8-16 cm	> 16 cm
Average error	4°	4°
Standard deviation (1S)	12°	10°

